

D-LAS Series

▶ D-LAS-44-ED-9.5x4-AC (Glas Pane Detection)

- Insensitive to outside light (alternating light operation, 100 kHz)
- Sensitivity setting via 5-step-switch
- Adjustment of gain factor via 3-revolution-potentiometer
- Receiving signal level indication by means of 3 LEDs
- Switching state indication by means of a super-bright yellow LED
- High-sensitive (starting from 0.5 mm strength of glass)
- Big transmitter/receiver distance (12 m)
- Big detecting range (laser spot 9.5 mm x 4 mm)
- Big receiver optics (easy adjustment of transmitter and receiver optics)



D-LAS-44-ED-9.5x4-AC-R (Receiver)



Design

Product name:

Transmitter: D-LAS-ED1-4x9.5-T or
D-LAS-ED1-9.5x4-T

Receiver: D-LAS-44-ED-9.5x4-AC-R (two-piece)

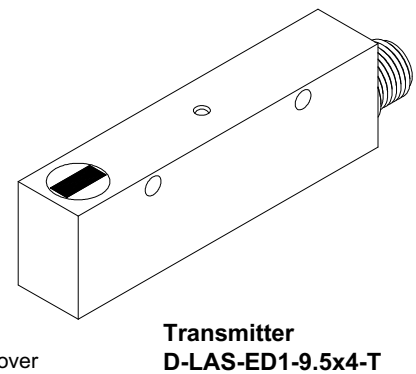
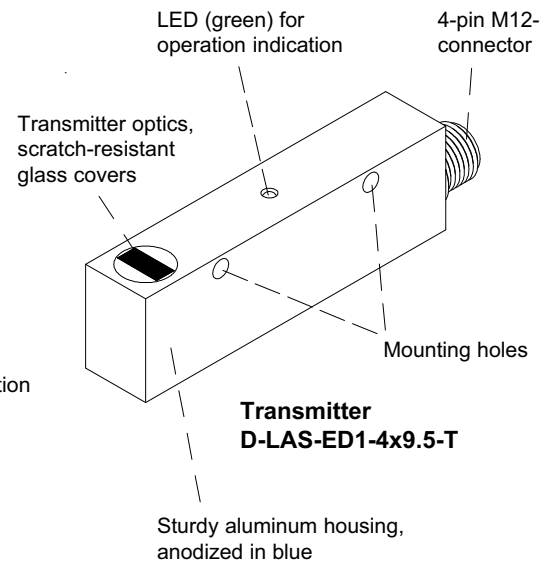
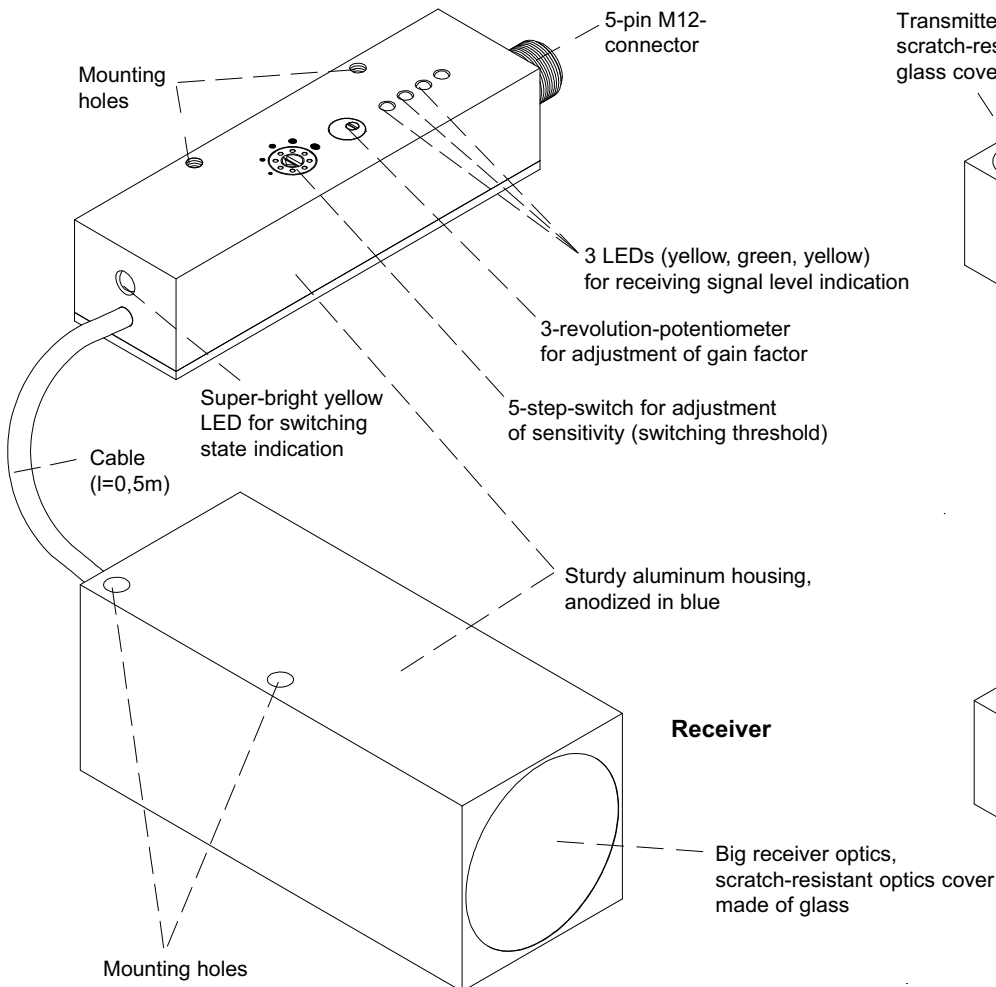



Technical Data

Model	D-LAS-ED1-4x9.5-T or D-LAS-ED1-9.5x4-T (transmitter) D-LAS-44-ED-9.5x4-AC-R (receiver)
Laser	Solid state laser, 670 nm, DC-operation, 1 mW max. opt. power, laser class 2 acc. to DIN EN 60825. The use of these laser transmitters therefore requires no additional protective measures.
Max. range	typ. 12 m
Min. detectable strength of glass	0.5 mm
Beam dimensions at transmitter output	typ. 9.5 mm x 4 mm
Optical filter	Red light filter RG630
Beam divergency	typ. 1 mrad
Voltage supply	+12VDC ... +32VDC, reversed-polarity protected, overcurrent protected
Pulsating light/ Direct light operation	Pulsating light (100 kHz)
Ambient light	Up to 5000 Lux
Sensitivity setting (switching threshold)	Adjustable by means of an integrated 5-step-switch (step 1: 93%, step 2: 90%, step 3: 87%, step 4: 83%, step 5: 80%)
Gain factor (analog signal)	Adjustable by means of an integrated potentiometer (3 revolutions)
Current consumption	Transmitter: typ. 50 mA Receiver: typ. 70 mA
Switching frequency	typ. 1 kHz
Switching outputs	Pin 2 (white): Analog output (0 ... +10V) Pin 4 (black): Output Q _{inv} (npn bright-switching, pnp dark-switching) Pin 5 (grey): Output dirt accumulation
Enclosure rating	IP67
Operating temperature range	-20°C ... +50°C
Storage temperature range	-20°C ... +85°C
Housing	Aluminum, anodized in blue
Housing dimensions	Transmitter: approx. 92 mm x 24 mm x 16 mm (incl. M12 connector) Receiver: approx. 113 mm x 28 mm x 24 mm (incl. M12 conn.) respectively approx. 105 mm x 44 mm x 44 mm
Connector type	Transmitter: M12, 4-pin (stainless steel pug) Receiver: M12, 5-pin (stainless steel plug)
Max. switching current	100 mA, short-circuit-proof
EMC test acc. to	IEC - 801...
Switching state indication	By means of an integrated super-bright yellow LED (receiver)
Receiving signal level indication	3 LEDs: yellow/green/yellow

Dimensions

D-LAS-44-ED-9.5x4-AC-R (Receiver, two-piece):

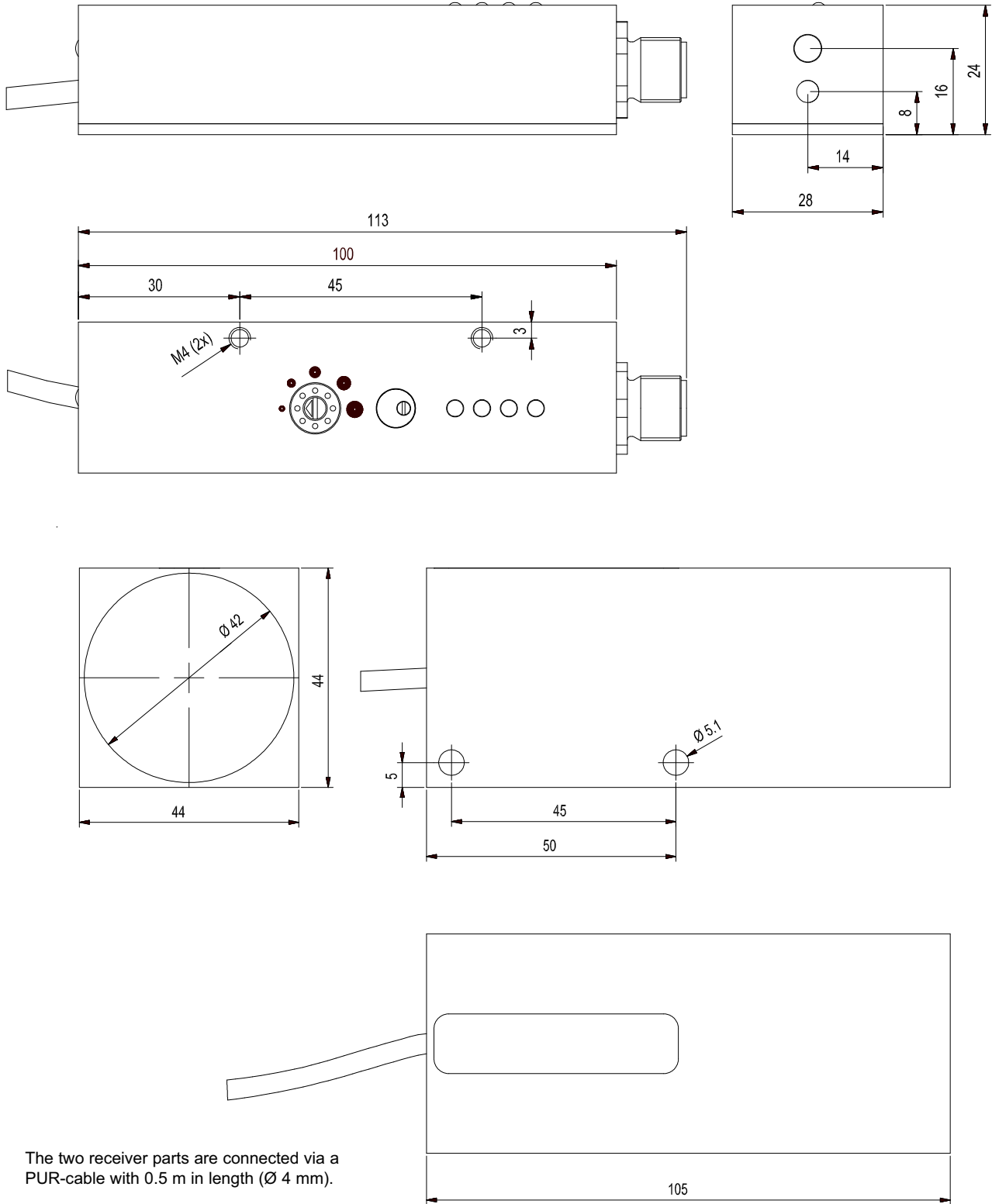

The two receiver parts are connected via a PUR-cable with 0.5 m in length ($\varnothing 4$ mm).

All dimensions in mm

Dimensions

D-LAS-ED1-4x9.5-T
D-LAS-ED1-9.5x4-T
(Transmitter):

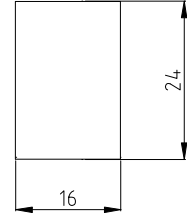
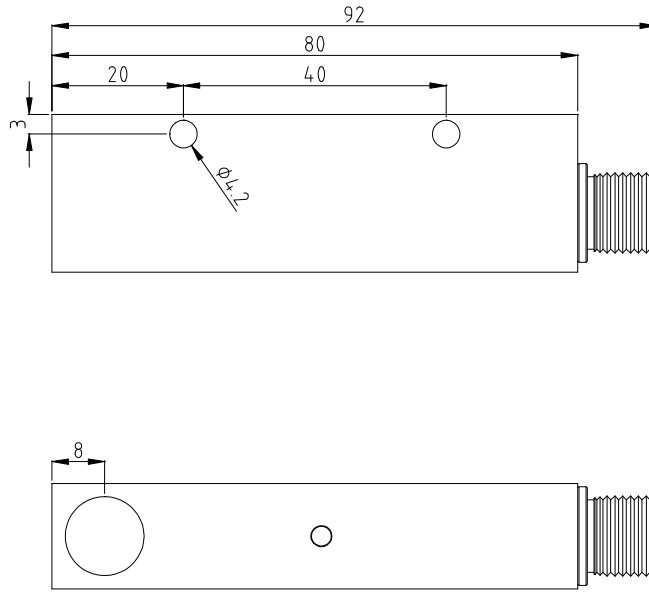

All dimensions in mm

Mounting

Mounting accessories:
(please order separately)

Mounting plates for
D-LAS-ED1-4x9.5-T
D-LAS-ED1-9.5x4-T:

MOUNT-GD1-H-T (for horizontal mounting)
MOUNT-GD1-V-T (für vertical mounting)

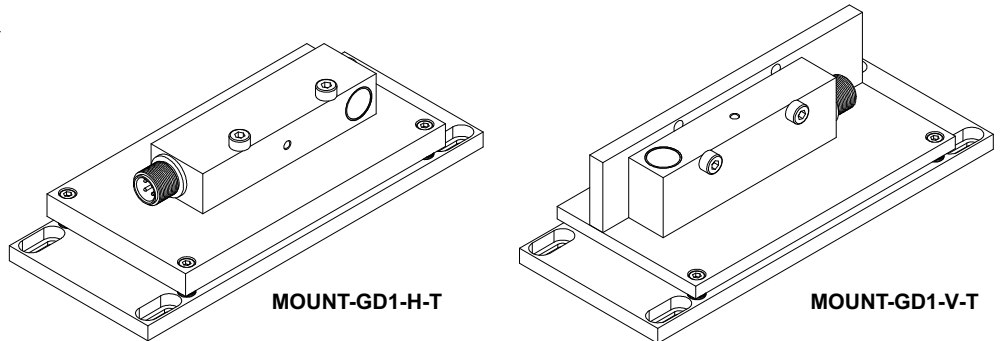

Laser Warning

The transmitters of the laser one-way light barriers of D-LAS Series comply with laser class 2 according to EN 60825. The use of these laser transmitters therefore requires no additional protective measures.

The transmitters of the D-LAS Series are supplied with a laser warning label.

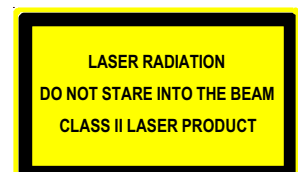



Setting

D-LAS-44-ED-9.5x4-AC-R (Receiver):

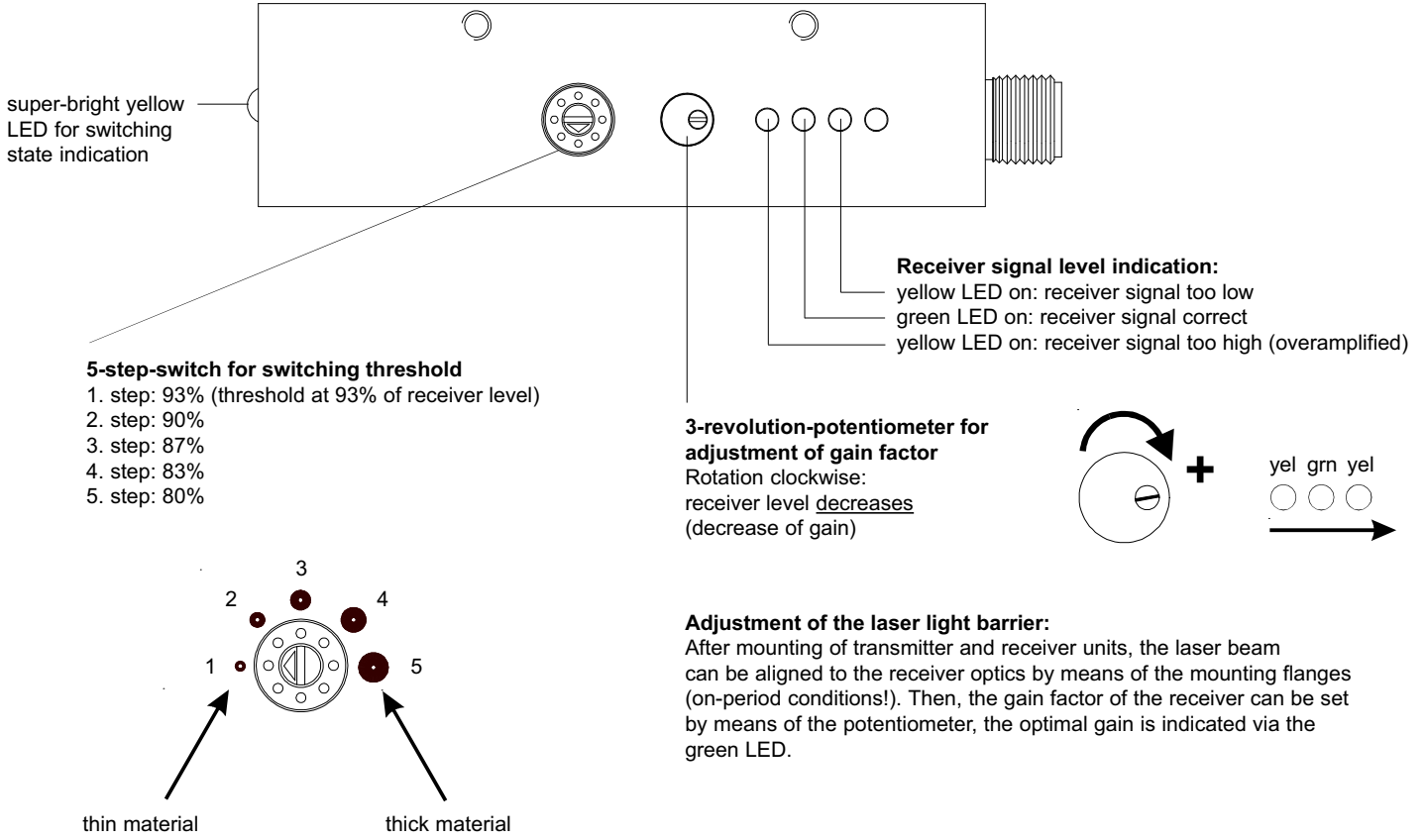

Connector Assignment

**D-LAS-ED1-4x9.5-T
 D-LAS-ED1-9.5x4-T
 (Transmitter):**

Pin No.:	(color)	Assignment:
1	(brown)	+Ub (+12 ... +30VDC)
2	(white)	n.c.
3	(blue)	GND (0V)
4	(black)	n.c.
Shield		Housing

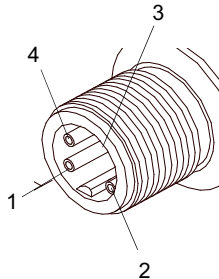

Connecting cable for transmitter:

cab-M12/4-g-2-shd

(PUR-cable shielded, length 2m, 4-pin M12 female connector)

D-LAS-44-ED-9.5x4-AC-R (Receiver):

Pin No.:	(color)	Assignment:
1	(brown)	+Ub (+12 ... +30VDC)
2	(white)	ANALOG (0V ... +10V)
3	(blue)	GND (0V)
4	(black)	Output INV „Qinv“
5	(grey)	Output DIRT ACCUMULATION

Connecting cable for receiver:

cab-M12/5-g-2

(PUR-cable, length 2m, 5-pin M12 female connector)

High-precision triggering on thin glass panes starting from a thickness of 0.5 mm

In various glass handling plants, glass panes up to a height or width of several meters have to be positioned with highest accuracy (in the 0.1 mm range).

The problem is aggravated by the fact that the glass pane may have a thickness of 0.5 mm. With hardened glass, bending of several millimeters must also be taken into consideration. Moreover, when vibrations occur at the facilities the laser spot must not leave the receiver optics input area.

For safe detection of the glass pane, a correspondingly large detection area (9.5 mm x 4 mm laser light band) must be available on the one hand, and on the other hand it must be possible to set a correspondingly high sensitivity.

In this case, sensitivity setting is effected in 5 steps by step switches; a potentiometer is used to set the proper gain (3 LEDs as setting aid: 1 x green, 2 x yellow). One digital signal (bright-, dark-switching), one analog signal (0V ... +10V), and one signal for dirt accumulation are provided at the output. The operating frequency is 1 kHz.

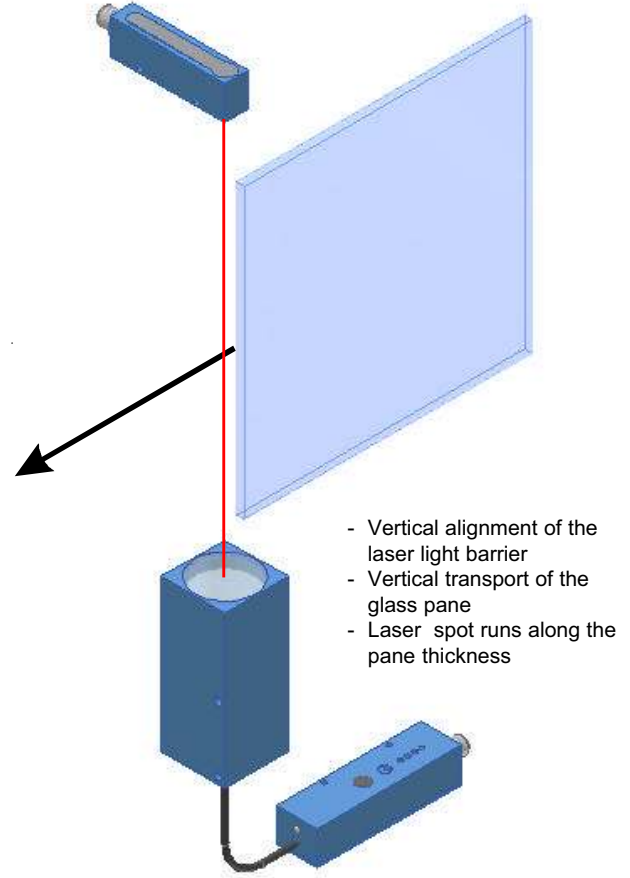
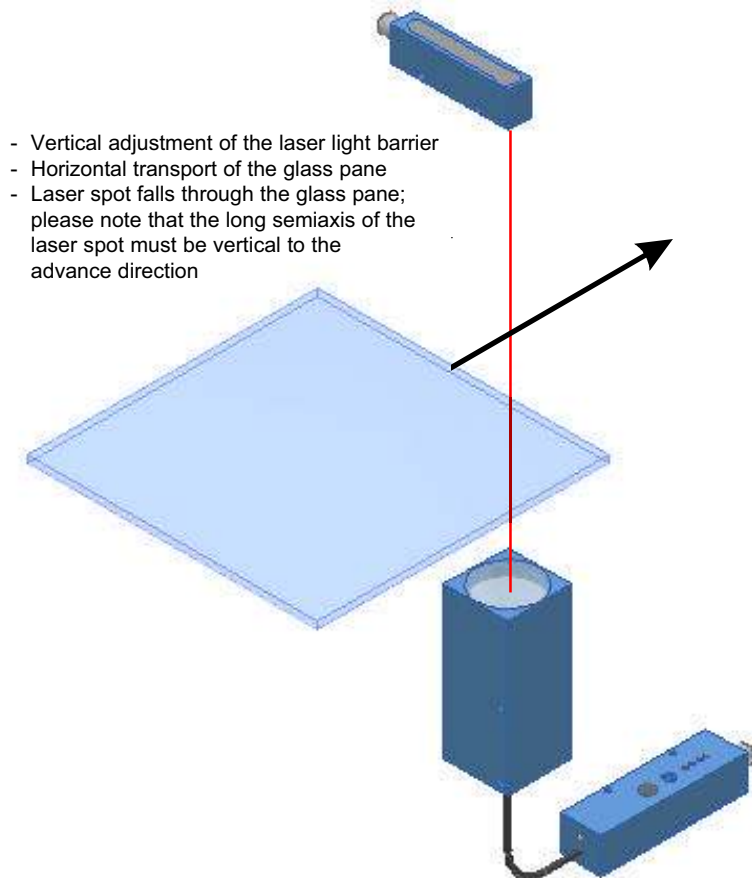



Application Examples

- Horizontal alignment of the laser light barrier
- Horizontal transport of the glass panes
- Laser spot runs along the pane thickness

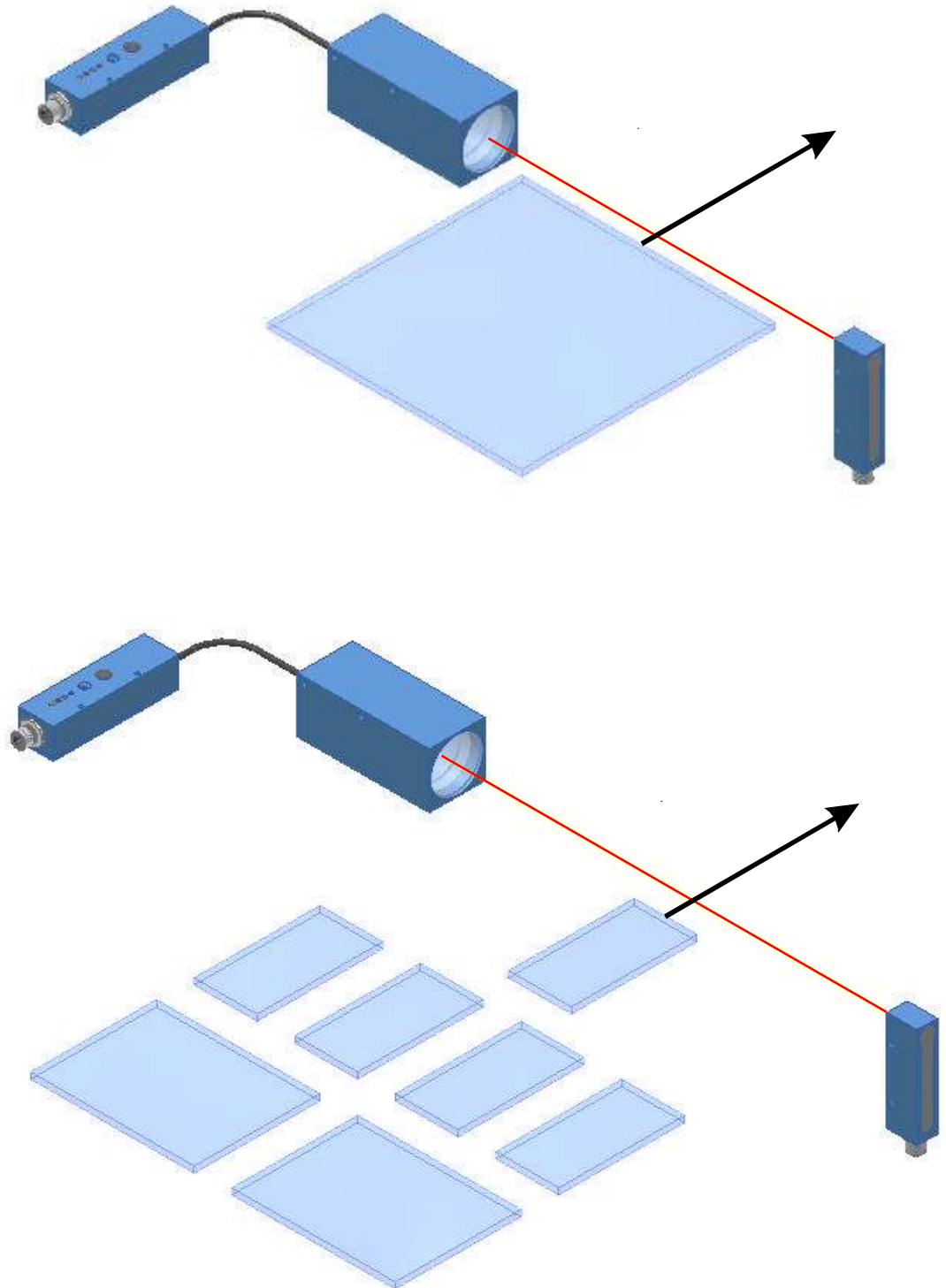



Notes